

F61 Series Standard Flow Switches

Installation

IMPORTANT: All F61 Series Flow Switches are intended to control equipment under normal operating conditions. Where failure or malfunction of an F61 Flow Switch could lead to an abnormal operating condition that could cause personal injury or damage to the equipment or other property, other devices (limit or safety controls) or systems (alarm or supervisory) intended to warn of, or protect against, failure or malfunction of the F61 Flow Switch must be incorporated into and maintained as part of the control system.

Some models of the F61 Series Standard Flow Switches require installation or adjustment of paddles prior to mounting. See *Installing the Flow Paddles*.

Parts Included

Standard models of the F61 flow switch include an installed three-piece flow paddle. Some models also include a large flow paddle for large pipe sizes.

Table 1: Replacement Parts

Kit Number	Description
KIT21A-600	Stainless Steel Three-piece Paddle (3 in., 2 in., and 1 in. Segments)
KIT21A-601	Stainless Steel 6 in. Paddle
PLT52A-600R	Stainless Steel Three-piece Paddle (3 in., 2 in., and 1 in. Segments) and 6 in. Paddle
CVR62A-600R	Replacement Cover Assembly for LB, MB, MD, and MG types

Installing the Flow Paddles

IMPORTANT: To allow the switch to detect changes in the fluid flow, the flow paddle must not touch the pipe or any restrictions in the pipe.

Adjust flow paddles to the size of the pipe used. If needed, trim the large flow paddle at the arc corresponding to pipe size (see Figure 1 and Figure 2) and install.

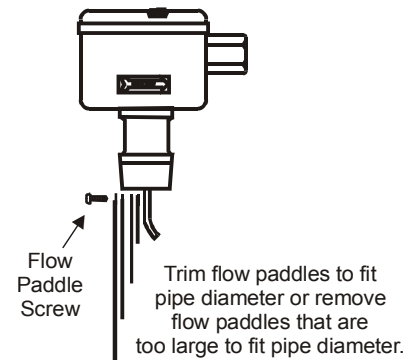

Figure 1: Installing the Paddles

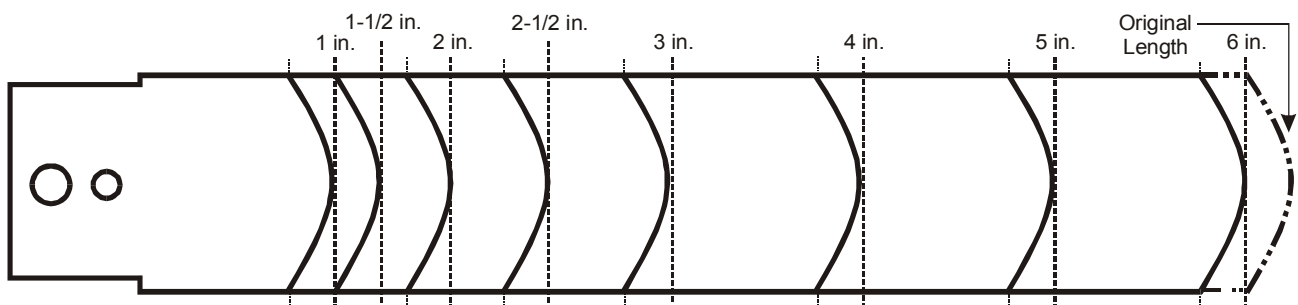

Figure 2: Trimming Diagram for Large Flow Paddle

Dimensions

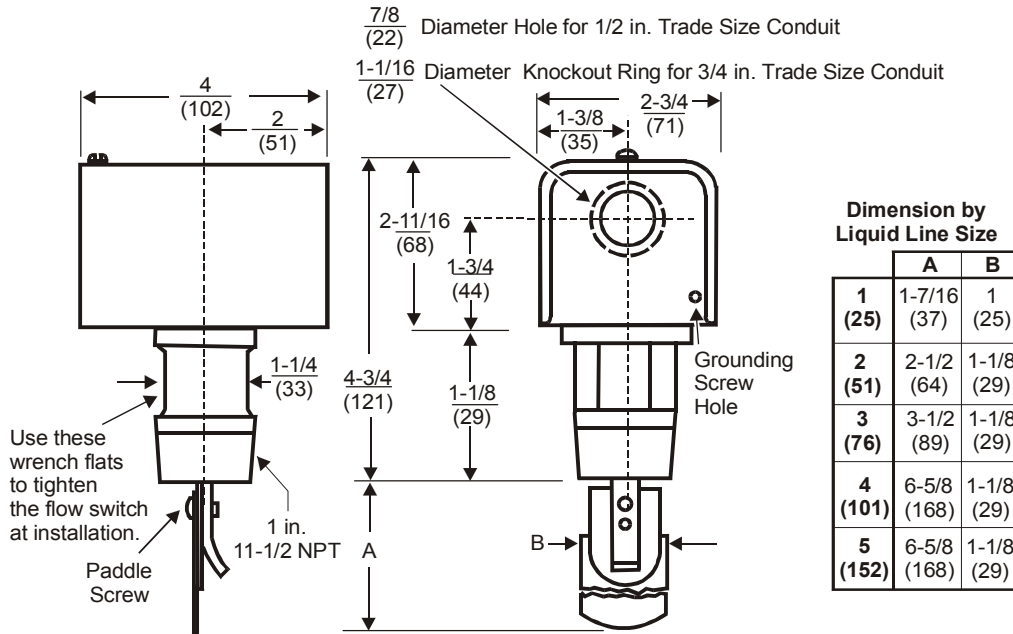

Figure 3: NEMA 1 Enclosure (F61KB Types) Dimensions, in./mm

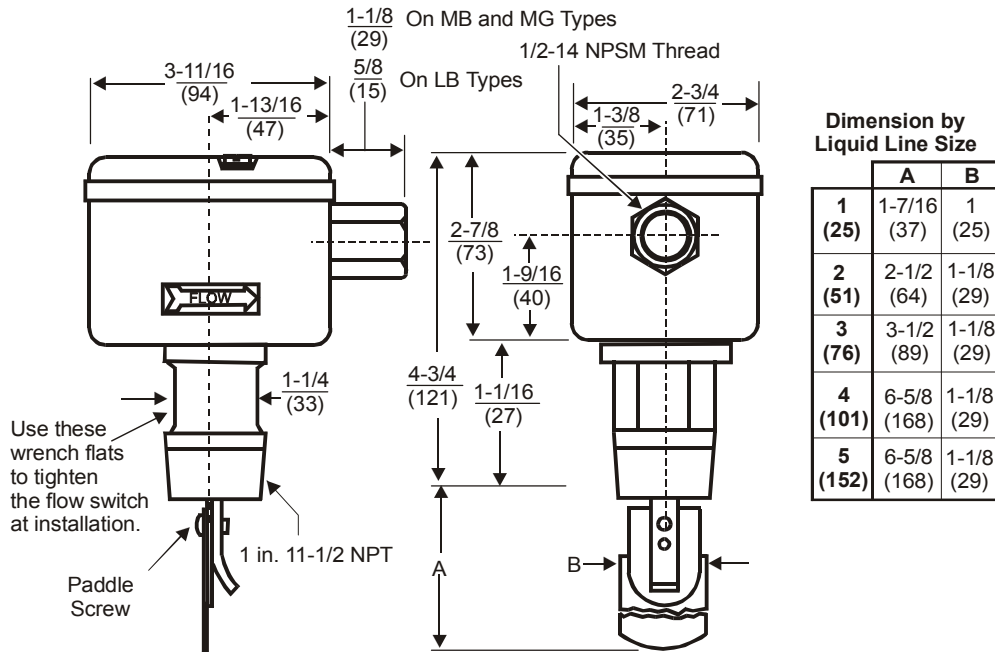

Figure 4: NEMA 3 or NEMA 3R Enclosure (F61LB, F61MB, F61MG Types) Dimensions, in./mm

Mounting



CAUTION: Risk of Equipment Damage.

To avoid damaging the switch, do not tighten the switch to the tee by grasping the switch enclosure. Use only the wrench flats provided.

Mount the F61 Series Flow Switch, using the following guidelines:

- Install the switch so that the cover and interior are accessible.
- Mount the switch so that the flow of fluid is in the direction of the arrow on the switch casing.
- Use a pipe union on each side of the flow switch to allow easy removal or replacement.
- Mount the switch so that the pipe does not extend too far into the flow switch casing.
- Use pipe thread sealer on male threads only.
- Do not remove the cover gasket or the wire grommet from the conduit opening.

For 1 in. pipe installation, mount the F61 flow switch in a standard 1 in. x 1 in. x 1 in. tee. For larger sizes of pipe, use a reducing tee to keep the flow switch close to the pipe and provide adequate paddle length in the flow stream.

Example: Use a 2 in. x 2 in. x 1 in. tee for a 2 in. pipe. If a standard 2 in. x 2 in. x 2 in. tee is used, install a face or hex bushing in the top opening to reduce it to 1 in.

Mount the flow switch so the terminals or wire leads are easily accessible for wiring. Screw the flow switch in position so the flat of the paddle is at a right angle to the flow. The arrow on the side of the case must point in the direction of the flow.

Location Considerations

Mount the F61 flow switch in a horizontal pipeline or a vertical pipeline with upward fluid flow. Do not use in a vertical pipeline with downward flow. When mounted in a vertical pipe with upward flow, the switch trips at a slightly higher flow than shown in Table 3 through Table 6, due to the effect of gravity on the switch mechanism.

Mount the F61 flow switch in a section of pipe where there is a straight run of at least five pipe diameters on each side of the flow switch from the nearest elbow, valve, or other pipe restriction. See Figure 5.

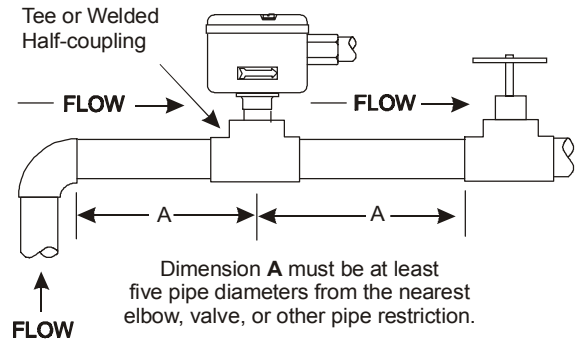

Figure 5: Required Piping Distance

Do not subject the flow switches to water hammer. Use a suitable water hammer arrester if a fast-closing valve is located downstream of the flow switch. See Figure 6.

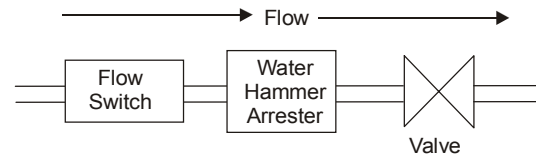

Figure 6: Water Hammer Arrester Location Schematic

Wiring



WARNING: Risk of Electrical Shock.

Disconnect power supply before making electrical connections. Failure to follow this precaution may result in electrical shock or death.



CAUTION: Risk of Equipment Damage.

Using terminal screws other than those provided will void the warranty and may damage the switch. Use only the terminal screws furnished.

IMPORTANT: To prevent moisture from entering and condensate from forming inside the NEMA 3R enclosure, do not remove the cover gasket or the wire grommet from the conduit opening.

IMPORTANT: Install all wiring in accordance with the National Electrical Code and local regulations. Make all wiring connections using copper conductors only. Do not exceed the control's electrical rating.

The F61KB and F61LB models have three color-coded terminals. Red is common. See Table 2 and Figure 1 for switch action.

The F61MB and F61MG models have four color-coded wire leads. Red is common, green is ground. See Table 2.

Table 2: Switch Action

Flow Action	Switch Closure
Increase	Red to Yellow
Decrease	Red to Blue

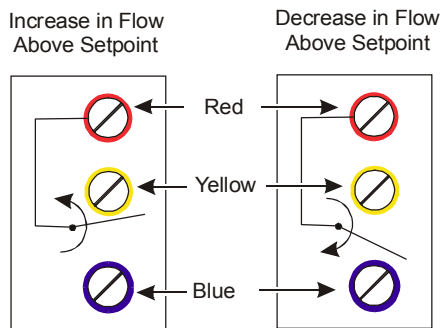

Figure 7: Switch Action

Setup and Adjustments



WARNING: Risk of Electrical Shock.

Disconnect power supply before making electrical connections. Failure to follow this precaution may result in electrical shock or death.



CAUTION: Risk of Improper Operation.

The switch is factory set at approximately the minimum flow rate (see Table 3 through Table 6). Do not set lower than the factory setting because that may result in the switch failing to return to a **no flow** position.



CAUTION: Risk of Equipment Damage.

Sealed settings (screws marked with black paint) are not intended to be changed. Adjustment attempts may damage the control or cause loss of calibration, voiding the warranty.

To adjust the setting of the flow switch:

1. Disconnect power supply before making electrical connections.
2. Remove the F61 flow switch cover.
3. Turn the adjusting screw **clockwise** to **raise** the flow rate. Turn the adjusting screw **counterclockwise** to **lower** the flow rate. See Figure 8.
4. Replace the cover after completing adjustments. Tighten the cover screws to 12 in-lbs of torque.

Note: Do **not** lower the flow rate unless it has been raised from the factory setting.

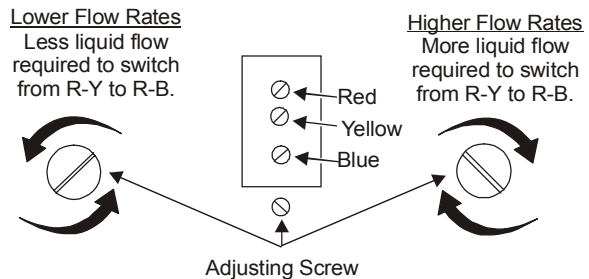

Figure 8: Flow Rate Adjustment

To verify that the flow rate is set above the factory minimum (see Figure 9):

1. depress the main lever numerous times. If the lever fails to click upon return at any time, the flow rate is set below the factory-set minimum.
2. raise the flow rate to approximately the factory minimum by turning the adjusting screw clockwise until the lever clicks upon return every time.

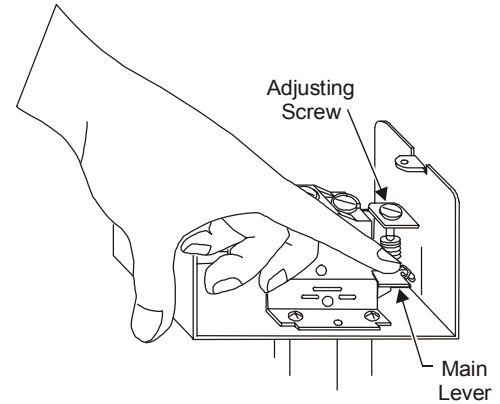

Figure 9: Minimum Adjustment

Typical Flow Rates for Standard F61 Flow Switches

Table 3: F61KB, F61LB, and F61MB Models, 1-3 in. Paddles

Pipe Size (in.)		GPM (m ³ /hr) Required to Actuate Switch									
		1	1-1/4 ¹	1-1/2 ¹	2	2-1/2 ²	3	4 ³	5 ³	6 ³	8 ³
Minimum Adjustment	Flow Increase (R to Y Closes)	4.20 (0.95)	5.80 (1.32)	7.50 (1.70)	13.7 (3.11)	18.0 (4.09)	27.5 (6.24)	65.0 (14.8)	125 (28.4)	190 (43.2)	375 (85.2)
	Flow Decrease (R to B Closes)	2.50 (0.57)	3.70 (0.84)	5.00 (1.14)	9.50 (2.16)	12.5 (2.84)	19.0 (4.32)	50.0 (11.4)	101 (22.9)	158 (35.9)	320 (72.7)
Maximum Adjustment	Flow Increase (R to Y Closes)	8.80 (2.0)	13.3 (3.02)	19.2 (4.36)	29.0 (6.59)	34.5 (7.84)	53.0 (12.0)	128 (29.1)	245 (55.6)	375 (85.2)	760 (173)
	Flow Decrease (R to B Closes)	8.50 (1.93)	12.5 (2.84)	18.0 (4.09)	27.0 (6.13)	32.0 (7.27)	50.0 (11.4)	122 (27.7)	235 (53.4)	360 (81.8)	730 (166)

1. Values for 2 in. paddle trimmed to fit pipe.
2. Values for 3 in. paddle trimmed to fit pipe.
3. Values calculated for factory-installed set of 1, 2, and 3 in. paddles.

Table 4: F61KB, F61LB, and F61MB Models, 6 in. Paddles*

Pipe Size (in.)		GPM (m ³ /hr) Required to Actuate Switch			
		4	5	6	8
Minimum Adjustment	Flow Increase (R to Y Closes)	37.0 (8.40)	57.0 (12.9)	74.0 (16.8)	205 (46.6)
	Flow Decrease (R to B Closes)	27.0 (6.13)	41.0 (9.31)	54.0 (12.3)	170 (38.6)
Maximum Adjustment	Flow Increase (R to Y Closes)	81.0 (18.4)	118 (26.8)	144 (32.7)	415 (94.3)
	Flow Decrease (R to B Closes)	76.0 (17.3)	111 (25.2)	135 (30.7)	400 (90.8)

* Where paddle size is larger than pipe size, values are for 6 in. paddle trimmed to fit pipe.

Table 5: F61MG Models, 1-3 in. Paddles

Pipe Size (in.)		GPM (m ³ /hr) Required to Actuate Switch									
		1	1-1/4 ¹	1-1/2 ¹	2	2-1/2 ²	3	4 ³	5 ³	6 ³	8 ³
Minimum Adjustment	Flow Increase (R to Y Closes)	3.80 (0.86)	5.30 (1.20)	6.90 (1.57)	12.7 (2.88)	16.7 (3.79)	24.3 (5.52)	61.0 (13.8)	118 (26.8)	183 (41.6)	362 (82.2)
	Flow Decrease (R to B Closes)	2.50 (0.57)	3.70 (0.84)	5.00 (1.14)	9.50 (2.16)	12.5 (2.84)	19.0 (4.32)	50.0 (11.4)	101 (22.9)	158 (35.9)	320 (72.7)
Maximum Adjustment	Flow Increase (R to Y Closes)	8.70 (1.98)	13.1 (2.98)	18.8 (4.27)	28.9 (6.56)	33.7 (7.65)	52.1 (11.8)	126 (28.6)	243 (55.2)	372 (84.5)	753 (171)
	Flow Decrease (R to B Closes)	8.50 (1.93)	12.5 (2.84)	18.0 (4.09)	27.0 (6.13)	32.0 (7.27)	50.0 (11.4)	122 (27.7)	235 (53.4)	360 (81.8)	730 (166)

1. Values for 2 in. paddle trimmed to fit pipe.
2. Values for 3 in. paddle trimmed to fit pipe.
3. Values calculated for factory-installed set of 1, 2, and 3 in. paddles.

Table 6: F61MG Models, 6 in. Paddles*

Pipe Size (in.)		GPM (m ³ /hr) Required to Actuate Switch			
		4	5	6	8
Minimum Adjustment	Flow Increase (R to Y Closes)	35.0 (7.95)	53.0 (12.0)	69.0 (15.7)	197 (44.7)
	Flow Decrease (R to B Closes)	27.0 (6.13)	41.0 (9.31)	54.0 (12.3)	170 (38.6)
Maximum Adjustment	Flow Increase (R to Y Closes)	80.0 (18.2)	116 (26.3)	142 (32.2)	412 (93.6)
	Flow Decrease (R to B Closes)	76.0 (17.3)	111 (25.2)	135 (30.7)	400 (90.8)

* Where paddle size is larger than pipe size, values are for 6 in. paddle trimmed to fit pipe.

Checkout

IMPORTANT: Ensure installation, wiring, and control settings are according to the application requirements. Refer to the controlled system's manufacturer specifications for the proper settings when adjusting these controls.

Apply power to the control and controlled equipment. Cycle the controlled system at least three times at normal operating conditions.

The circuit between the red and the yellow leads (terminals) closes when sufficient fluid flows through the pipe to trip the F61 flow switch.

Troubleshooting

Use the information in Table 7 to troubleshoot the flow switch.

Repairs and Replacement

Do not make field repairs, except for replacement of the cover and paddles. For a replacement flow switch, paddle kit or cover, contact the nearest Johnson Controls/PENN™ distributor. For more information, contact Refrigeration Application Engineering at (800) 275-5676.

Table 7: Troubleshooting

Symptom/Problem	Solution
Water (condensate) is within the enclosure.	Use a model with a NEMA 3R enclosure. If using a model with a NEMA 3R enclosure, inspect the grommet in the conduit fitting. Replace grommet if defective.
Fluid from the tank is leaking into enclosure due to bellows failure.	Replace flow switch.
Switch does not activate due to debris caught within the switch mechanism.	Clear any debris within the switch mechanism. Test the operation of switch several times for proper operation.
Control switch action is reversed.	Ensure connections follow wiring diagrams.
Control does not switch.	Check connections.
Switch fails to return to the no flow position.	Switch is set lower than the factory setting. Increase the setting. On vertical pipes, ensure that direction of flow is up. The arrow on switch must point in direction of flow (up).
Control does not switch on flow increase.	Check for cracked/broken paddle. Replace if necessary.

Electrical Ratings

Table 8: Electrical Ratings for F61KB, F61LB, and F61MB Models

Electrical Ratings	120 VAC	208 VAC	240 VAC	277 VAC
Horsepower	1	1	1	-
Full Load Amperes	16.0	8.8	8.0	-
Locked Rotor Amperes	96.0	52.8	48.0	-
Non-inductive Amperes	16.0	16.0	16.0	16.0
Pilot Duty	125 VA at 24/277 VAC			

Table 9: Electrical Ratings for F61MG Models

Electrical Ratings	120 VAC
Full Load Amperes	1
Locked Rotor Amperes	6
Non-inductive Amperes	2
Pilot Duty	125 VA at 24/277 VAC

Technical Specifications

Product	F61 Series Standard Flow Switches
Maximum Fluid Pressure	150 psig (1034 kPa)
Minimum Fluid Temperature	32°F (0°C) (F61KB, F61LB) -20°F (-29°C) (F61MB, F61MG)
Maximum Fluid Temperature	250°F (121°C)
Switch	Single Pole Double Throw
Wiring Connections	Screw Type Terminals (F61KB, F61LB) Four Color-coded No. 14 AWG Solid Conductor Wire Leads, 7 in. (178 mm) Long (F61MB, F61MG)
Pipe Connector	1 in. 11-1/2 NPT Threads
Conduit Connection	One 7/8 in. (22 mm) Hole for 1/2 in. Conduit with 1-1/8 in. (29 mm) Knockout Ring for 3/4 in. Conduit (F61KB) Female Hub for 1/2 in. Conduit, 1/2-14 NPSM Threads (F61LB, F61MB, F61MG)
UL Listed	E5368, CCN NMFT
Agency Listings	CSA Certified LR948, Class 3211 06, Class 4813 02, Class 1222 01 (F61KB) (F61LB - Not CSA Certified) LR948, Class 3211 06 (F61MB, F61MG)
Shipping Weight	2.8 lb (1.3 kg)

The performance specifications are nominal and conform to acceptable industry standards. For application at conditions beyond these specifications, consult the local Johnson Controls office. Johnson Controls, Inc. shall not be liable for damages resulting from misapplication or misuse of its products.

Refer to the *F61 Series Flow Switches Product/Technical Bulletin (LIT-125225)* for necessary information on operating and performance specifications of this product.



Controls Group
507 E. Michigan Street
P.O. Box 423
Milwaukee, WI 53201

Printed in U.S.A.
www.johnsoncontrols.com